

## SUCTION LANCES

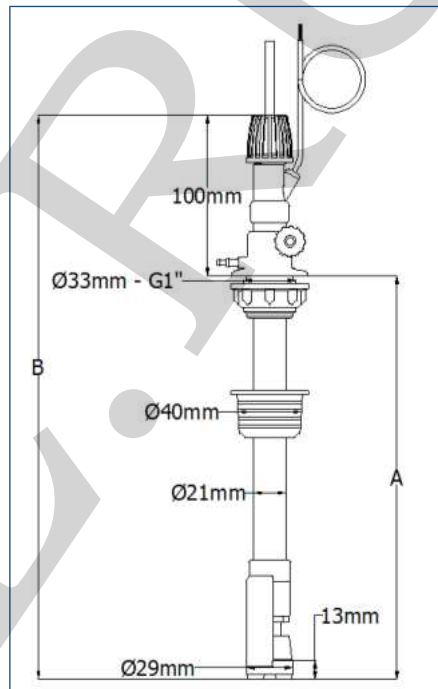

To complete the range of accessories for dosing stations, are available suction lances of adaptable length with connection for purge tube 4x6 (8x12 on request), complete with built-in non-return valve and level sensor, suitable for dosing stations with tanks up to 1000 litres.



- Flow rate up to 100 litres/h
- Mounting with 1" threaded ring or sleeve
- PP-PVC-NBR body
- Pyrex ball valve (PTFE on request)
- FPM seals (EPDM on request)
- Level probe with 2 m cable totally protected
- Working temperature: max 50°C

Tank (volume)	Dimensions		Level probe with connector for pumps	Code
	Total length (B)	Variable length (A)		
50 litres	490 mm	115 → 390 mm	EF110/EF150/EF155	9700.0610
			PAB/PAC/PDF/PDS	9700.1610
			EF125/EF160	9700.2610
100 litres	700 mm	115 → 600 mm	EF110/EF150/EF155	9700.0611
			PAB/PAC/PDF/PDS	9700.1611
			EF125/EF160	9700.2611
150 – 300 litres	940 mm	115 → 840 mm	EF110/EF150/EF155	9700.0612
			PAB/PAC/PDF/PDS	9700.1612
			EF125/EF160	9700.2612
500 – 1000 litres	1420 mm	115 → 1320 mm	EF110/EF150/EF155	9700.0613
			PAB/PAC/PDF/PDS	9700.1613
			EF125/EF160	9700.2613

**Note:** The codes listed in the above table refer to lances with FPM seals. Upon order, all models are also available with EPDM seals.